

(19)



Europäisches Patentamt

European Patent Office

Office européen des brevets



(11)

EP 0 677 284 B1

(12)

EUROPEAN PATENT SPECIFICATION

(45) Date of publication and mention
of the grant of the patent:
09.06.1999 Bulletin 1999/23

(51) Int. Cl.⁶: **A61F 13/15**

(21) Application number: **95103693.8**

(22) Date of filing: **14.03.1995**

(54) **Containment flap, method of making same and absorbent article comprising same**

Aufnahmelasche, Herstellungsverfahren dafür und saugfähiger Artikel mit solcher Lasche
Rabat de retention, procédé pour sa fabrication et article absorbant pourvu d'un tel rabat

(84) Designated Contracting States:
BE DE ES FR GB IT NL SE

(30) Priority: **14.03.1994 US 213338**

(43) Date of publication of application:
18.10.1995 Bulletin 1995/42

(73) Proprietor:
KIMBERLY-CLARK WORLDWIDE, INC.
Neenah, Wisconsin 54956 (US)

(72) Inventor:
Kielpikowski, David Peter
Appleton, WI 54915 (US)

(74) Representative:
Diehl, Hermann, Dr. Dipl.-Phys. et al
DIEHL, GLÄSER, HILTL & PARTNER
Patentanwälte
Augustenstrasse 46
80333 München (DE)

(56) References cited:

EP-A- 0 243 013	EP-A- 0 246 858
EP-A- 0 409 149	EP-A- 0 411 287
EP-A- 0 565 058	EP-A- 0 566 150
EP-A- 0 567 105	EP-A- 0 568 085
GB-A- 2 270 247	

Note: Within nine months from the publication of the mention of the grant of the European patent, any person may give notice to the European Patent Office of opposition to the European patent granted. Notice of opposition shall be filed in a written reasoned statement. It shall not be deemed to have been filed until the opposition fee has been paid. (Art. 99(1) European Patent Convention).

EP 0 677 284 B1

Description

[0001] The present invention relates to containment flaps, a method for their construction and to absorbent articles comprising these containment flaps.

[0002] Various containment flaps are known for use in connection with absorbent articles such as infant diapers, training pants, adult incontinence products and the like. Such containment flaps are generally employed along the longitudinal sides of an absorbent article such as a diaper. The containment flaps are generally thought to be particularly well suited for the containment of fecal matter and to prevent the lateral flow of liquid waste until such time as the liquid waste can be absorbed by the absorbent article.

[0003] Containment flaps are often used in connection with elasticized leg cuffs located at the leg openings of the absorbent article which leg cuffs perform an additional gasketing function.

[0004] Many constructions of containment flaps are known. Such containment flaps generally comprise a proximal edge, intended to be attached to the absorbent article, and an opposite distal edge which is generally not attached to the absorbent article along at least a portion of its length. An elastic member is generally located adjacent the distal edge to assist in maintaining the containment flap in an upright condition and in maintaining a sealing relationship between the distal edge of the containment flap and the body of a wearer during use. The elastic member is generally located between two layers of material so that the elastic does not come into contact with the body of a wearer. Typically, the containment flaps are formed by folding the material from which the containment flap is to be formed in a longitudinal direction such that the fold line defines the distal edge of the containment flap with the opposite longitudinal ends of the material forming the proximal edge of the containment flap. In this manner, the elastic member is encased by the folded edge of the material such that it cannot contact the body of a wearer during use.

[0005] In order to allow the elastic material to gather the containment flap and assist in maintaining it in an upright position, the elastic material is generally adhesively attached to the containment flap. Adhesive attachment of the elastic member to the containment flap results in a certain amount of the elastic nature of the elastic member being destroyed. Specifically, at the points where the elastic member is adhesively attached to the containment flap, the elastic member is no longer capable of being stretched. That is, it is no longer "elastic". Moreover, the use of adhesives to attach the elastic material, or in joining the two layers of material, has been found, in some instances, to undesirably affect the stiffness of the containment flap.

[0006] Finally, known methods of constructing containment flaps tend to be relatively complex such that they may be a rate-limiting factor in certain continuous processes for producing absorbent articles.

[0007] EP-A-0 411 287 describes a garment with a waste containment pocket defined by spaced elasticized flaps and a method for producing the same. The flaps are formed by placing two elastic members onto a layer and applying an adhesive.

[0008] EP-A-0 568 085 describes a containment flap as mentioned in the preamble of claim 1 and a method in which the two elastic elements are provided on a sheet and adhered thereto by use of an adhesive.

[0009] Accordingly, it is the object of the present invention to provide a containment flap which is generally flexible and relatively easy to manufacture and which may be more economically manufactured and produced than certain known containment flaps and to provide a method for the construction of such containment flaps and absorbent articles employing such containment flaps.

[0010] This object is solved by the containment flap according to independent claims 1 and 12, the absorbent article according to independent claim 22, and the method of making a containment flap according to independent claims 24 and 34. Further advantageous features, aspects and details of the present invention are evident from the dependent claims, the description and the drawings. The claims are intended to be understood as a first non-limiting approach to defining the invention in general terms.

[0011] In one aspect, the present invention provides a containment flap for use on an absorbent article, which has a proximal edge adapted to be joined to the absorbent article and a distal edge opposite said proximal edge. The containment flap comprises a first layer of heat-fusible material, a second layer of heat-fusible material, and an elastic member located between said first and second layers adjacent the distal edge of the containment flap.

[0012] In a preferred embodiment of this aspect of the present invention, a first pattern of thermal bonds joins said first and second layers together. The first pattern of thermal bonds is located between the elastic member and the distal edge such that the elastic member is prevented from contacting the skin of a wearer. In a specific embodiment of this aspect of the present invention, the elastic members are adhesively joined to said first layer.

[0013] In a second preferred embodiment of this aspect of the present invention, a pattern of intermittent, thermal bonds joins said first and second layers together and intermittently, thermally bonds said elastic member to said first and second layer.

[0014] In a third preferred embodiment of this aspect of the present invention, said first and second layers are formed from a single, integral piece of material which is folded upon itself. A pattern of intermittent, thermal bonds joins said first and second layers together and intermittently, thermally bond said elastic member to said first and second layer.

[0015] In another aspect, the present invention provides an absorbent article having a front portion, a rear

portion, and a crotch portion connecting the front and rear portions. The crotch portion has opposite longitudinal side portions. The absorbent article comprises a liquid-permeable bodyside liner, an outer cover, and an absorbent core located between the bodyside liner and the outer cover. A pair of containment flaps extends longitudinally from the front portion of the absorbent article to the rear portion. The containment flaps have a proximal edge and a distal edge opposite the proximal edge. The proximal edge is joined to the bodyside liner in the crotch portion and in the front and rear portions. The containment flaps comprise a first layer of heat-fusible material, a second layer of heat-fusible material, and an elastic member located between the first and second layers of heat-fusible material adjacent the distal edge.

[0016] In a first preferred embodiment of this aspect of the present invention, a first pattern of thermal bonds joins said first and second layers together. The first pattern of thermal bonds is located between the elastic member and the distal edge such that the elastic member is prevented from contacting the skin of a wearer. In a specific embodiment of this aspect of the present invention, the elastic members are adhesively joined to said first layer.

[0017] In a second preferred embodiment of this aspect of the present invention, a pattern of intermittent, thermal bonds joins said first and second layers together and intermittently, thermally bonds said elastic member to said first and second layer.

[0018] In a third preferred embodiment of this aspect of the present invention, said first and second layers are formed from a single, integral piece of material which is folded upon itself. A pattern of intermittent, thermal bonds joins said first and second layers together and intermittently, thermally bonds said elastic member to said first and second layers.

[0019] In another aspect, the present invention provides a method of making a containment flap for use on an absorbent article. The method comprises providing a first layer of heat-fusible material traveling in a first direction. Two elastic members traveling in the first direction are attached to the first layer in a laterally-spaced relationship. A second layer of heat-fusible material traveling in the first direction is thermally bonded to the first layer to form a composite having first and second longitudinal side edges. The second layer of heat-fusible material is bonded to the first layer of heat-fusible material such that the elastic members are located between the first and second layers and such that a first pattern of thermal bonds is located between the elastic members. The composite is slit in the first direction between the elastic members to form two slit composites. The slit composites are then cut in a second direction perpendicular to said first direction to form a containment flap.

[0020] In another aspect, the present invention provides a method of making a containment flap for use on an absorbent article, which comprises providing a sin-

gle, integral piece of heat-fusible material; folding said piece of heat-fusible material to provide first and second layers of heat-fusible material; positioning an elastic member between said first and second layers of heat-fusible material; and intermittently, thermally bonding said elastic member to said first and second layers.

Fig. 1 illustrates a partial cutaway plan view of a containment flap according to one embodiment of the present invention.

Fig. 2 illustrates a partial cutaway plan view of a containment flap according to a second embodiment of the present invention.

Fig. 3 illustrates a partial cutaway plan view of a third embodiment of a containment flap according to the present invention.

Fig. 4 illustrates a partial cutaway plan view of a fourth embodiment of a containment flap according to the present invention.

Fig. 5 illustrates a top plan view of a diaper according to the present invention.

Fig. 6 illustrates a cross-sectional perspective view taken along line 6-6 of Fig. 5.

Fig. 7 illustrates a schematic illustration of a method for producing containment flaps according to the present invention.

Fig. 8 illustrates a top plan view of the containment flap as it is produced according to the method of Fig. 7.

Fig. 9 illustrates a cross-sectional view taken along line 9-9 of Fig. 8.

Fig. 10 is a cross-sectional view of the containment flap illustrated in Fig. 9 in position on a diaper.

[0021] In one aspect, the present invention provides a containment flap for use on an absorbent article. This aspect of the present invention can best be understood by reference to the drawings in which like numerals represent like elements. Fig. 1 illustrates a partial cutaway top plan view of a containment flap according to the present invention. In Fig. 1, containment flap 10 defines a proximal edge 12, adapted to be joined to an absorbent article, and a distal edge 14 opposite the proximal edge 12. Containment flap 10 comprises a first layer of heat-fusible material 16, a second layer of heat-fusible material 18, and an elastic member 20 located between the first layer 16 and the second layer 18. The elastic member 20 is positioned adjacent distal edge 14.

[0022] A first pattern of thermal bonds 22 joins the first

and second layers of heat-fusible material together. The first pattern of thermal bonds 22 is located between the elastic member 20 and the distal edge 14 such that the elastic member 20 is prevented from contacting the skin of a wearer when the containment flap is used on an absorbent article.

[0023] A second embodiment of a containment flap 10 according to the present invention is illustrated in Fig. 2. Again, the containment flap defines a proximal edge 12 and a distal edge 14 located opposite the proximal edge 12. The containment flap is formed from a first layer of heat-fusible material 16 and a second layer of heat-fusible material 18. In this embodiment, two elastic members 20 are located between the first and second layers adjacent the distal edge 14. The two elastic members 20 are adhesively attached to the first layer 16 by adhesive 24.

[0024] Fig. 3 illustrates a partial cutaway plan view of a third embodiment of a containment flap according to the present invention. In the embodiment illustrated in Fig. 3, containment flap 10 includes intermittent, thermal bonds 30 which join said first and second layers together and intermittently, thermally bond said elastic members to said first and/or second layers. Containment flap 10 may include the first pattern of thermal bonds 22 and may further comprise a second pattern of thermal bonds 26 bonding the first and second layers of heat-fusible material together. The second pattern of thermal bonds is located between the elastic member 20 and the proximal edge 12. In this way, a channel 28 is formed between the first and second layers of heat-fusible material. The elastic member 20 is located in channel 28.

[0025] Fig. 4 illustrates a partial cutaway plan view of a fourth embodiment of a containment flap according to the present invention. In the embodiment illustrated in Fig. 4, containment flap 10 is formed from a single, integral piece of material which is folded to define distal edge 14, the first layer of heat-fusible material 16 and the second layer of heat-fusible material 18. Elastic member 20 is located between the first and second layers of heat-fusible material. Intermittent, thermal bonds 30 join said first and second layers together and intermittently, thermally bond said elastic member to said first and/or second layers. The containment flap 10 may also comprise thermal bonds 25 which further bond said first and second layers together.

[0026] The containment flaps illustrated in Figs. 1-4 are adapted for use on absorbent articles. Typically, the containment flaps will be attached to the absorbent article at or adjacent proximal edge 12. At least a portion of the distal edge 14 will be unattached to the absorbent article such that the containment flap 10 provides a barrier to the lateral flow of waste material.

[0027] A wide range of materials are suitable for use as the first and second layers of heat-fusible material. A material will be considered to be heat fusible when an applied thermal energy causes it to soften or melt such

that it can be joined to another material. As used herein, reference to "thermal bonds", "thermal bonding", "thermally bonded", "thermally attached" and the like refer to bonding caused by the application of thermal energies, such as heat, ultrasonic energy, infra red energy, and the like.

[0028] Specific examples of materials suitable for use as the first and second layers of heat-fusible material include nonwoven materials, such as spunbond or melt-blown thermoplastic polymers, such as polyolefins; bonded carded webs; film materials, such as polyolefin, ethylene vinyl acetate, ethyl methacrylate, and polyester films; foam materials, such as polyolefin foams; woven materials, such as woven polypropylene, polyethylene or polyester fabrics; and composites and laminates of the above nonwoven, film, foam, and woven materials. In a specific embodiment of the present invention, such as that illustrated in Fig. 1, the first and second heat-fusible materials are non-integrally formed. That is, the first and second layers of heat-fusible material represent separate elements which are not joined other than by thermal, adhesive, or similar attaching techniques. Specifically, the first and second layers are not formed from an integral piece of material through a folding process. In another specific embodiment of the present invention, such as that illustrated in Fig. 4, the first and second heat-fusible layers are integrally formed. That is, the first and second layers are formed from a single, integral piece of material through a folding process. If the containment flap of Fig. 3 is formed from a single, integral piece of material, the presence of thermal bonds 22 causes the distal edge to "blouse" when in use on an absorbent product.

[0029] In another specific embodiment, the first and second layers of heat-fusible materials are formed from a nonwoven material such as a spunbond or meltblown polyethylene or polypropylene material. When it is desired to provide a containment flap which is generally liquid pervious, the spunbond material will suitably be treated with a surfactant to render it generally hydrophilic. Alternatively, one of the first or second layers of heat-fusible material may be treated with a surfactant while the other layer is treated to a lesser extent with a surfactant or is not treated with a surfactant. In this case, a containment flap which is less pervious to liquid will be produced. Still further, if it is desired to produce a containment flap which is generally liquid impervious, one of the first or second layers of heat-fusible material can comprise a liquid-impervious film, such as a polyolefin film.

[0030] In one specific embodiment, the first layer of heat-fusible material comprises a polypropylene spunbond material having a basis weight of about 14.0 grams per square meter (about 0.4 ounce per square yard) and being formed from fibers having a tex (denier) of about 0.27-0.43 (about 2.5-3.8 d), which material is treated with a surfactant commercially available from Rohm and Haas Company, Philadelphia, PA, under the

trade designation Triton X-102, at an add-on rate of about 0.3 weight percent. The second layer of heat-fusible material comprises a spunbond/meltblown composite formed from polypropylene and having a basis weight of about 28.0 grams per square meter (about 0.8 ounce per square yard) and comprising from about 50 percent spunbond material and about 50 percent meltblown material.

[0031] The elastic member 20 may comprise any elastomeric material capable of being elongated at least about 50 percent, alternately at least about 250 percent, alternately at least about 350 percent, and capable of recovering to a length within at least about 75 percent, more particularly, at least about 50 percent of its elongated length (original length plus elongation). The elastic member may be in the form of ribbons, individual strands, or other configurations. In one embodiment, the elastic member is in the form of individual elastomeric threads of elastomeric material. As described above, the containment flaps may comprise a single, elastic member or two or more elastic members. In one specific embodiment, the elastic member comprises a 470 decitex Lycra® thread commercially available from E. I. DuPont de Nemours and Co. Alternatively, the elastic member 20 can be composed of a thermoplastic elastomer or a natural or synthetic rubber commercially available from J.P.S. Elastomerics Corp. The elastic member 20 can also be composed of a heat-activatable elastic material such as Pebax®, commercially available from Atochem, Inc., which can be activated with heat treatment after the association with the containment flap.

[0032] In the specific embodiments illustrated in Figs. 3 and 4, the elastic member is intermittently, thermally attached to the first and/or second layer of heat-fusible material. Specifically, intermittent, thermal bonds 30 soften or partially melt the first and/or second layers 16 and 18 so that they become thermally bonded. The elastic member 20 is trapped by the softened or melted material forming the first and/or second layers 16 and 18. It is generally desired that elastic member 20 not be melted or decomposed in the area of intermittent, thermal bond 30 so that the integrity of the elastic member 20 is retained along the length of the containment flap. Accordingly, the melting point or decomposition point of the elastic member 20 should be greater than the softening and/or melting point of the first and/or second layers of heat-fusible materials. Specifically, the melting point or decomposition point of the elastic member 20 may be at least about 5 degrees Centigrade, more specifically, at least about 10 degrees Centigrade greater than the melting point of the first and/or second layers of heat-fusible material. In this manner, the first and second layers of heat-fusible material may be melt bonded together so as to entrap and hold the elastic member 20 without causing the elastic member 20 to melt or decompose.

[0033] In the specific embodiment illustrated in Fig. 2,

two elastic members 20 are shown as being adhesively attached to the first layer 16 by adhesive 24. Those skilled in the art will recognize that a wide variety of adhesive materials are suitable for use as adhesive 24. Specifically, the adhesive 24 may comprise a hot melt adhesive, a pressure-sensitive adhesive, latex adhesive, and the like. In one specific embodiment, the adhesive 24 comprises a hot melt adhesive commercially available from Findley Adhesives, Inc. under the trade designation H2096. The adhesive 24 may be applied in a wide variety of patterns known to those skilled in the art. Specifically, the adhesive 24 may be applied in swirls, strands, strips, bars, spots, and the like, and may be applied via slot coating, spraying, printing, and the like. Those skilled in the art will recognize that, at the points at which elastic member 20 is adhered to the first layer of heat-fusible material, the elastic nature of the elastic member is destroyed. That is, the elastic cannot be stretched over that length of the elastic member 20 which is adhesively attached to the first substrate. In order to compensate for the partial deadening of the elastic nature of the elastic member 20, it is generally desirable to use an elastic member having sufficient contractive forces to compensate for the partial loss of elastic nature caused by adhesive 24.

[0034] Similarly, in the embodiments illustrated in Figs. 3 and 4, the elastic nature of the elastic member 20 is destroyed in the area of intermittent, thermal bonds 30. However, the intermittent, thermal bonds 30 generally provide a stronger attachment to the first layer 16 than do the adhesive bonds created by adhesive 24 illustrated in Fig. 2. Thus, it is possible to space the thermal bonds 30 a greater distance apart than is generally done with the use of adhesives, such as illustrated in Fig. 2.

[0035] Specifically, the thermal bonds 30 may be spaced so that they are located only at the longitudinal ends of the flaps. They may also be intermittently spaced from about 10 cm (about 4 inches) to about 1 cm (about 0.4 inch) apart. Further, the thermal bonds 30 may be placed in a pattern of varying spacing allowing for increased bonding or decreased elastic retraction along the length of the flap. When the flaps are produced in a process, such as that illustrated below in connection with Figs. 7 and 8, the intermittent, thermal bonds may be located so that, when individual flaps are formed (such as by the cuts made by cutter 80 described in connection with Fig. 7 below), the elastic member retracts from the longitudinal ends of the flaps to the thermal bond 30. This creates an area of the containment flap which is free of elastics. This area which is free of elastics is suitably at least about 2.54 cm (about 1 inch) in length, particularly about 2.54 cm (about 1 inch) to about 12.7 cm (about 5 inches) in length.

[0036] Due to the greater spacing between thermal bonds 30, it is generally possible to use an elastic member having less contractive forces in the embodiment

illustrated in Figs. 3 and 4 than in that embodiment illustrated in Fig. 2. Alternatively, it may be possible to use a single, elastic member in the embodiment illustrated in Figs. 3 and 4, while it may be desirable to use at least two of the same elastic members in the embodiment illustrated in Fig. 2.

[0037] The first pattern of thermal bonding illustrated in Figs. 1-3 serves to provide a seal along distal edge 14 such that the elastic member 20 cannot contact the skin of a wearer during use. In the past, distal edge 14 was often formed by folding. In this manner, elastic member 20 was prevented from contacting the skin of a wearer during use. However, the process to form such a folded distal edge was, in certain instances, undesirably complex. The use of the first pattern of thermal bonds to join the first and second layers together, such that the elastic member 20 is prevented from contacting the skin of a wearer, allows for the more efficient production of containment flaps.

[0038] Further, when the first pattern of thermal bonds joins first and second nonintegral layers together, it is possible to form shaped or curved containment flaps. Specifically, the distal edge of the containment flaps can be defined in a curved pattern, relative to the proximal edge, by the first pattern of thermal bonds. Excess material beyond the distal edge of the containment flap (as defined by the first pattern of thermal bonds) can then be trimmed and removed. In this manner, a containment flap, having different distances between its proximal and distal edges along its length, can be defined.

[0039] In the embodiments illustrated in Figs. 3 and 4, use of the intermittent, thermal bonds 30 to join the elastic member 20 to the first and second layers can result in the formation of a containment flap that does not require the presence of any adhesive. This allows for the production of a containment flap with improved softness. That is, the presence of adhesive introduces a degree of stiffness to the containment flap that can be avoided through the sole use of thermal bonds.

[0040] When it is desired to minimize the use of thermal bonds in the containment flap, it is possible to form the flap generally illustrated in Fig. 4.

[0041] Those skilled in the art will recognize that the first and second patterns of thermal bonds can be formed in a wide variety of ways. Specifically, the first pattern of thermal bonds can be formed by ultrasonic bonding, heat bonding, infrared bonding, and the like. Moreover, the pattern may be formed of a wide variety of geometric shapes, such as squares, circles, dots, ellipses, and the like. The first pattern of thermal bonds is generally formed such that the thermal bonds join, via melt bonding, the first and second layers together along at least about 10, more particularly at least about 30, and more particularly at least about 50 percent of the length of the containment flap.

[0042] The second pattern of thermal bonds illustrated in Fig. 3 may be the same as the first pattern of thermal

bonds or may be different. Specifically, it is believed that the second pattern of thermal bonds may comprise individual thermal bonds which are spaced further apart and thereby comprise a lower percent of the length of the containment flap than the first pattern of thermal bonds. This is because it is generally not as critical to prevent the elastic member from passing outside the second pattern of thermal bonds, as this would not cause the elastic member to contact the skin of a wearer.

[0043] Any method of forming the first and second patterns of thermal bonds is believed suitable for use in the present invention.

[0044] The thermal bonds 25 illustrated in Fig. 4 may be formed by any method and in any shape suitable for use in forming the first and second patterns of thermal bonds.

[0045] Figs. 5 and 6 illustrate a diaper according to the present invention. While the specific embodiments of the present invention will be described in terms of a disposable infant diaper adapted to be worn by infants about the lower torso, it is to be understood that the present invention is equally applicable to other absorbent articles, such as adult incontinence garments, training pants, feminine care products, and the like. With reference to Figs. 5 and 6, diaper 32 defines a front portion 34, a rear portion 36, and a crotch portion 38 connecting the front and rear portions. The crotch portion has opposite longitudinal side portions 40. Specifically, diaper 32 comprises an outer cover 42, a bodyside liner 44, and an absorbent core 46 located between the bodyside liner 44 and the outer cover 42. When used herein, reference to a front portion refers to that part of the diaper which is generally located on the front of an infant when in use. Reference to the rear portion refers to the portion of the diaper generally located at the rear of the infant when in use, and reference to the crotch portion refers to that portion which is generally located between the legs of an infant when in use.

[0046] The crotch portion 38 has opposite longitudinal side portions 40 which comprise a pair of elasticized, longitudinally-extending leg cuffs 48. The leg cuffs 48 are generally adapted to fit about the legs of a wearer when in use and serve as a mechanical barrier to the lateral flow of body exudates. Leg cuffs 48 are elasticized by leg elastics 50. Diaper 32 further comprises front waist elastic 52 and rear waist elastic 54. The rear portion 36 of diaper 32 also comprises fastening means, such as tape fasteners 56. The tape fasteners 56 are intended to hold the diaper 32 about the waist of an infant when in use.

[0047] Further, diaper 32 comprises containment flaps 10 such as those illustrated in Figs. 1-4. In the specific embodiment illustrated in Figs. 5 and 6, the diaper 32 comprises a containment flap such as that illustrated in Fig. 4. The containment flap 10 is attached to bodyside liner 44 along proximal edge 12 in the front, rear, and crotch portion of the diaper 32. The distal edge 14 of

containment flap 10 is adhered to the bodyside liner 44 of diaper 32 in at least a portion of the front and rear portion of diaper 32. In this way, elastic members 20 function to maintain the distal edge of containment flap 10 in an upright condition in the crotch portion of diaper 32 when in use on a wearer.

[0048] Bodyside liner 44 suitably presents a body-facing surface which is compliant, soft feeling and non-irritating to the wearer's skin. Further, bodyside liner 44 may be less hydrophilic than the absorbent core 46, to present a relatively dry surface to the wearer, and is sufficiently porous to be liquid permeable, permitting liquid to readily penetrate through its thickness. A suitable bodyside liner may be manufactured from a wide selection of web materials, such as porous foams, reticulated foams, apertured plastic films, natural fibers (for example, wood or cotton fibers), synthetic fibers (for example, polyester or polypropylene fibers), or a combination of natural and synthetic fibers. Bodyside liner 44 is suitably employed to help isolate the wearer's skin from liquids held in absorbent core 46.

[0049] Various woven and nonwoven fabrics can be used for bodyside liner 44. For example, the bodyside liner may be composed of a meltblown or spunbonded web of polyolefin fibers. The bodyside liner may also be a bonded-carded web composed of natural and/or synthetic fibers. The bodyside liner may be composed of a substantially hydrophobic material, and the hydrophobic material may, optionally, be treated with a surfactant, or otherwise processed, to impart a desired level of wettability and hydrophilicity. In a particular embodiment of the present invention, the bodyside liner 44 comprises a nonwoven, spunbond, polypropylene fabric composed of about 0.31-0.36 tex (about 2.8-3.2 denier) fibers formed into a web having a basis weight of about 22 grams per square meter and a density of about 0.06 gram per cubic centimeter. The fabric is surface treated with about 0.28 weight percent of a surfactant commercially available from Rohm and Haas Co. under the trade designation Triton X-102.

[0050] The outer cover 42 may suitably be composed of a material which is either liquid permeable or liquid impermeable. It is generally preferred that the outer cover 42 be formed from a material which is substantially impermeable to liquids. For example, a typical outer cover can be manufactured from a thin plastic film or other flexible liquid-impermeable material. For example, the outer cover 42 may be formed from a polyethylene film having a thickness of from about 0.012 mm (0.5 mil) to about 0.051 mm (2.0 mils). If it is desired to present the outer cover 42 with a more clothlike feeling, the outer cover 42 may comprise a polyethylene film having laminated to the outer surface thereof a nonwoven web, such as a spunbond web of polyolefin fibers. For example, a polyethylene film having a thickness of about 0.015 mm (0.6 mil) may have thermally laminated thereto a spunbond web of polyolefin fibers, which fibers have a thickness of about 0.16 to 0.28 tex (about 1.5

to 2.5 denier) per filament, which nonwoven web has a basis weight of about 24 grams per square meter (0.7 ounce per square yard). Methods of forming such clothlike outer covers are known to those skilled in the art.

[0051] Further, the outer cover may be formed of a woven or nonwoven fibrous web layer which has been totally or partially constructed or treated to impart a desired level of liquid impermeability to selected regions that are adjacent or proximate the absorbent core 46. Still further, the outer cover 42 may optionally be composed of a micro-porous "breathable" material which permits vapors to escape from the absorbent core 46 while still preventing liquid exudates from passing through the outer cover 42.

[0052] The absorbent core 46 suitably comprises a matrix of hydrophilic fibers, such as a web of cellulosic fluff, mixed with particles of a high-absorbency material commonly known as superabsorbent material. In a particular embodiment, absorbent core 46 comprises a mixture of superabsorbent hydrogel-forming particles and wood pulp fluff. The wood pulp fluff may be exchanged with synthetic, polymeric, meltblown fibers or with a combination of meltblown fibers and natural fibers. The superabsorbent particles may be substantially homogeneously mixed with the hydrophilic fibers or may be non-uniformly mixed.

[0053] Alternatively, the absorbent core may comprise a laminate of fibrous webs and superabsorbent material or other suitable means of maintaining a superabsorbent material in a localized area.

[0054] The absorbent core 46 may have any of a number of shapes. For example, the absorbent core may be rectangular, I-shaped or T-shaped. It is generally preferred that the absorbent core be narrower in the crotch portion than the rear or front portion.

[0055] The high-absorbency material can be selected from natural, synthetic and modified natural polymers and materials. The high-absorbency materials can be inorganic materials, such as silica gels, or organic compounds, such as crosslinked polymers. The term "crosslinked" refers to any means for effectively rendering normally water-soluble materials substantially water insoluble but swellable. Such means can include, for example, physical entanglement, crystalline domains, covalent bonds, ionic complexes and associations, hydrophilic associations, such as hydrogen bonding, and hydrophobic associations or Van der Waals forces.

[0056] Examples of synthetic, polymeric, high-absorbency materials include the alkali metal and ammonium salts of poly(acrylic acid) and poly(methacrylic acid), poly(acrylamides), poly(vinyl ethers), maleic anhydride copolymers with vinyl ethers and alpha-olefins, poly(vinyl pyrrolidone), poly(vinyl morpholinone), poly(vinyl alcohol), and mixtures and copolymers thereof. Further polymers suitable for use in the absorbent core include natural and modified natural polymers, such as hydrolyzed acrylonitrile-grafted starch, acrylic acid grafted starch, methyl cellulose, carboxymethyl cel-

lulose, hydroxypropyl cellulose, and the natural gums, such as alginates, xanthum gum, locust bean gum, and the like. Mixtures of natural and wholly or partially synthetic absorbent polymers can also be useful in the present invention. Other suitable absorbent gelling materials are disclosed by Assarson et al. in U.S. Patent No. 3,902,236 issued August 26, 1975. Processes for preparing synthetic, absorbent gelling polymers are disclosed in U.S. Patent No. 4,076,663 issued February 28, 1978, to Masuda et al. and U.S. Patent No. 4,286,082 issued August 25, 1981, to Tsubakimoto et al.

[0057] The high-absorbency material may be in any of a wide variety of geometric forms. As a general rule, it is preferred that the high-absorbency material be in the form of discrete particles. However, the high-absorbency material may also be in the form of fibers, flakes, rods, spheres, needles, or the like.

[0058] As a general rule, the high-absorbency material is present in the absorbent core in an amount of from about 5 to about 100 weight percent based on total weight of the absorbent core.

[0059] The outer cover 42 and bodyside liner 44 are generally adhered to one another so as to form a pocket in which the absorbent core 46 is located. Thus, leg cuffs 48 are suitably formed by portions of the outer cover 42, and/or bodyside liner 44, which extend beyond the longitudinal sides of the absorbent core 46. Naturally, the leg cuffs 48 can also be formed from separate materials which are attached to the outer cover 42 and/or bodyside liner 44.

[0060] Leg cuffs 48 include leg elastics 50. Materials suitable for use in forming leg elastics 50 are known to those skilled in the art. Exemplary of such materials are strands or ribbons of a polymeric, elastomeric material which are adhered to the diaper at the leg cuff while in a stretched position, or which are attached to the diaper while the diaper is pleated, such that elastic constrictive forces are imparted to the leg cuff 48.

[0061] Similarly, waist elastics 52 and 54 and tape fasteners 56 suitable for use in the present invention are known to those skilled in the art.

[0062] A wide variety of other diaper configurations, as well as training pants, incontinence garments, and like configurations, are suitable for use in the present invention. Diapers suitable for use in the present invention are described in greater detail in commonly assigned U.S. Patent Application Serial No. 08/096,654 entitled "Thin Absorbent Article Having Rapid Uptake of Liquid" filed July 22, 1993, in the name of Hansen et al; and U.S. Patent No. 5,192,606 issued March 9, 1993, to Proxmire et al.

[0063] In a final aspect, the present invention provides methods of making a containment flap for use on an absorbent article. One method can best be understood by reference to Fig. 7 wherein a first layer of heat-fusible material 16 is provided from supply roll 58. The first layer of heat-fusible material 16 is traveling in a first

direction D. Two elastic members 20 are supplied from supply roll 60 and are traveling in the first direction D and are attached to the first layer of heat-fusible material in a laterally-spaced relationship. This can be seen by reference to Fig. 8. In the illustrated embodiment, elastic members 20 are attached to the first layer 16 by adhesive 24 applied from applicator 62. A second layer of heat-fusible material 18 is supplied from supply roll 64. The second layer of heat-fusible material is traveling in the first direction and is laid on top of the first layer 16 such that the elastic members 20 are located between the first and second layers. The composite 66, thus formed, then passes through nip roller 68. The composite 66 then passes through a thermal bonding means such as sonic bonder 70. As can be seen from reference to Fig. 8, the sonic bonder 70 thermally bonds the second layer of heat-fusible material to the first layer of heat-fusible material through thermal bonds 72 and 74. The composite 66 then passes through slit 76 wherein composite 66 is slit in the first direction between elastic members 20 to form two slit composites 78. The two slit composites 78 are then cut in a second direction D', generally perpendicular to said first direction, by cutter 80 to form containment flaps.

[0064] As can be seen from reference to Figs. 7-9, the thermal bonds 72, after being slit, form the first pattern of thermal bonds 22 illustrated in Figs. 1-3, while the thermal bonds 74 form the second pattern of thermal bonds 26 illustrated in Fig. 3.

[0065] While Figs. 7-9 illustrate that elastic members 20 are adhesively attached to the first layer 16, it is to be understood that applicator 62 could be removed from the process, such that elastic members 20 are merely laid on top of the first layer 16 and that elastic members 20 are subsequently intermittently, thermally attached to the first layer 16 by sonic bonder 70 in accordance with the embodiment of the present invention illustrated in Fig. 3. Containment flaps produced by the above method are then suitably attached to an absorbent article as illustrated and described in connection with Figs. 5 and 6.

[0066] Fig. 9 is a cross section of composite 66 taken along line 9-9 of Fig. 8. Line 82 illustrates where the composite 66 will be slit by slit 76.

[0067] As can be seen from reference to Fig. 9, the first layer of heat-fusible material is illustrated as being significantly wider than the second layer of heat-fusible material 18. In the illustrated embodiment, the first layer of heat-fusible material is a nonwoven material while the second layer of heat-fusible material 18 is a liquid-impervious material, such as a polyolefin film. Use of the containment flaps formed from the composite illustrated in Fig. 9 are shown in use in Fig. 10 which represents a cross-sectional view of an infant diaper similar to that illustrated in Fig. 5. As can be seen from reference to Fig. 10, the portion of the first layer 16 extending beyond the second layer 18 is used to form a portion of the bodyside liner 44 illustrated in Fig. 5. The second

layer 18 is located on the interior surface of the containment flap 10 illustrated in Fig. 10. Thus, the bodyside liner 44 illustrated in Fig. 10 actually comprises a portion of bodyside liner 44 located between containment flaps 10 and that portion of first layer 16 of the containment flap 10 which extends beyond the width of the second layer 18.

[0068] The containment flaps illustrated in Fig. 4 can be formed according to the following method. A single, integral piece of heat-fusible material is provided. The heat-fusible material is folded to provide first and second layers of heat-fusible material. An elastic member is positioned between the first and second layers of heat-fusible material. The elastic member is then intermittently, thermally bonded to said first and second layers.

[0069] While the invention has been described in detail with respect to specific embodiments thereof, it will be appreciated that those skilled in the art, upon attaining an understanding of the foregoing, may readily conceive of alterations to, variations of, and equivalents to these embodiments. Accordingly, the scope of the present invention should be assessed as that of the appended claims.

Claims

1. A containment flap (10) for use on an absorbent article, said containment flap (10) having a proximal edge (12), adapted to be joined to said absorbent article, and a distal edge (14) opposite said proximal edge (12), said containment flap (10) comprising:

a first layer (16);

a second layer (18);

at least one elastic member (20) located between said first and said second layers adjacent said distal edge (14); and

a first pattern of bonds (22) joining said first and second layers (16,18) together, said first pattern of bonds (22) being located between said elastic member (20) and said distal edge (14), characterized in that

said first and second layers (16,18) are made of heat-fusible material and said first pattern of bonds (22) is provided by thermal bonds.

2. The containment flap according to claim 1 wherein said first layer (16) comprises a nonwoven material.

3. The containment flap according to claim 1 or 2 wherein said second layer (18) comprises a nonwoven material.

4. The containment flap according to one of the preceding claims wherein said second layer (18) comprises a film.

5. The containment flap according to one of the preceding claims wherein said containment flap (10) comprises two elastic members (20).

6. The containment flap according to one of the preceding claims further comprising a second pattern of thermal bonds (26) located between said elastic member (20) and said proximal edge (12).

7. The containment flap according to one of the preceding claims wherein said elastic member (20) is adhesively attached to said first layer (16).

8. The containment flap according to one of the preceding claims wherein said first and second layers (16,18) are not integrally formed.

9. The containment flap according to one of the preceding claims wherein said elastic member (20) is intermittently, thermally attached to said first and/or second layers (16,18).

10. The containment flap according to one of the preceding claims wherein said elastic member (20) has a melting or decomposition point greater than the melting point of said first layer (16).

11. The containment flap according to one of the preceding claims wherein the melting or decomposition point of said elastic member (20) is at least 5°C greater than the melting point of said first layer (16).

12. The containment flap according to one of the preceding claims, wherein said elastic member (20) is intermittently, thermally attached to said first and second layers (16,18).

13. The containment flap according to one of the preceding claims wherein said containment flap (10) comprises a first pattern of thermal bonds (22) joining said first and second layers (16,18) together, said first pattern of thermal bonds (22) being adjacent said distal edge (14).

14. The containment flap according to one of the preceding claims wherein said containment flap (10) comprises a second pattern of thermal bonds (26) joining said first and second layers (16,18) together, said second pattern of thermal bonds (26) being located adjacent said first pattern of thermal bonds (22) and between said first pattern of thermal bonds (22) and said proximal edge (12).

15. The containment flap according to one of the pre-

ceding claims wherein said elastic member (20) is non-adhesively attached to said first or second layer (16,18).

16. The containment flap according to one of claims 9 to 15 wherein said elastic member (20) is not melted or decomposed during the intermittent, thermal attachment of said elastic member (20) to said first and/or second layers (16,18).
17. The containment flap according to one of claims 6 to 16 further comprising a second elastic member (20) located between said first and second patterns of thermal bonds (22,26), said second elastic member (20) being intermittently, thermally attached to said first and second layer (16,18).
18. The containment flap according to one of the preceding claims wherein said elastic member (20) comprises or is an elastomeric thread.
19. The containment flap according to claim 18 wherein said elastomeric thread has a melting or decomposition point greater than the melting point of said first and second layers (16,18).
20. The containment flap according to one of the preceding claims wherein said first and second layers (16,18) of heat-fusible material are formed from a single, integral piece of material by folding.
21. The containment flap according to one of the preceding claims wherein said containment flap (10) further comprises a second elastic member (20) located between said first and second pattern of thermal bonds (22,26).
22. An absorbent article (32) comprising the containment flap of one of claims 1 to 21.
23. The absorbent article (32) according to claim 22, having a front portion (34), a rear portion (36) and a crotch portion (38) connecting said front and rear portions (34,36), said crotch portion (38) having opposite longitudinal side portions (40), said article (32) comprising:

a liquid-permeable bodyside liner (44);

an outer cover (42);

an absorbent core (46) located between said bodyside liner (44) and said outer cover (42); and

a pair of containment flaps (10) extending longitudinally from said front portion (34) to said rear portion (36), wherein said proximal edge

(12) of said containment flap (10) is joined to said bodyside liner (44) in said crotch portion (38) and said front and rear portions (34,36).

24. A method of making a containment flap according to one of claims 1 to 21 for use on an absorbent article, said method comprising the following steps:
- providing a first layer of heat-fusible material traveling in a first direction;
- attaching two elastic members traveling in said first direction to said first layer in a laterally-spaced relationship;
- thermally bonding a second layer of heat-fusible material traveling in said first direction to said first layer to form a composite having first and second longitudinal side edges, such that said elastic member is located between said first and said second layers and such that a first pattern of thermal bonds is located between said elastic members;
- slitting said composite in said first direction between said elastic members to form two slit composites; and
- cutting said slit composites in a second direction perpendicular to said first direction to form containment flaps.
25. The method according to claim 24 wherein said first layer of heat-fusible material is a nonwoven material.
26. The method according to claim 24 or 25 wherein said second layer of heat-fusible material comprises a liquid-impervious film.
27. The method according to one of claims 24 to 26 wherein four elastic members are attached to said first layer in a laterally-spaced relationship.
28. The method according to one of claim 24 to 27 wherein a second pattern of thermal bonds is located between said first longitudinal side edge of said composite and one of said elastic members closest to said first longitudinal side edge and between said second longitudinal side edge of said composite and one of said elastic members closest to said second longitudinal side edge.
29. The method according to one of claims 24 to 28 wherein said elastic members are adhesively attached to said first layer.
30. The method of one of claims 24 to 29 wherein said

elastic members are intermittently, thermally attached to said first and second layers of heat-fusible material.

31. The method according to one of claims 24 to 30 wherein said elastic members are elastomeric threads. 5
32. The method according to one of claims 24 to 31 wherein said elastic members have a melting or decomposition point greater than the melting point of said first layer. 10
33. The method according to one of claims 24 to 32 wherein said elastic members have a melting or decomposition point at least 5°C greater than the melting point of said first layer. 15
34. A method of making a containment flap according to one of claims 1 to 21 for use on an absorbent article, said method comprising the following steps: 20

providing a single, integral piece of heat-fusible material;

folding said piece of heat-fusible material to provide first and second layers of heat-fusible material;

positioning an elastic member between said first and second layers of heat-fusible material; and 30

intermittently, thermally bonding said elastic member to said first and second layers. 35

Patentansprüche

1. Rückhalteklappe (10) zur Verwendung auf einem saugfähigen Artikel, wobei die Rückhalteklappe (10) eine proximale Kante (12) aufweist, welche mit dem saugfähigen Artikel verbunden werden kann, sowie eine gegenüber der proximalen Kante (12) angeordnete distale Kante (14), wobei die Rückhalteklappe (10) umfaßt: 40

eine erste Schicht (16);

eine zweite Schicht (18);

wenigstens ein elastisches Element (20), welches zwischen der ersten und der zweiten Schicht benachbart zu der distalen Kante (14) angeordnet ist; und 50

ein erstes Muster von Verklebungen (22), welche die erste und die zweite Schicht (16,18) miteinander verbinden, wobei das erste Muster 55

von Verklebungen (22) zwischen dem elastischen Element (20) und der distalen Kante (14) angeordnet ist, dadurch gekennzeichnet, daß

die erste und die zweite Schicht (16,18) aus einem wärmeschmelzbaren Material hergestellt sind und das erste Muster von Verklebungen (22) durch thermische Verklebungen erzeugt ist.

2. Rückhalteklappe gemäß Anspruch 1, bei der die erste Schicht (16) ein Vliesstoffmaterial aufweist.
3. Rückhalteklappe gemäß Anspruch 1 oder 2, bei der die zweite Schicht (18) ein Vliesstoffmaterial aufweist.
4. Rückhalteklappe gemäß einem der vorhergehenden Ansprüche, bei der die zweite Schicht (18) eine Folie aufweist.
5. Rückhalteklappe gemäß einem der vorhergehenden Ansprüche, bei der die Rückhalteklappe (10) zwei elastische Elemente (20) aufweist.
6. Rückhalteklappe gemäß einem der vorhergehenden Ansprüche, die des Weiteren ein zweites Muster von thermischen Verklebungen (26) aufweist, welches zwischen dem elastischen Element (20) und der proximalen Kante (12) angeordnet ist.
7. Rückhalteklappe gemäß einem der vorhergehenden Ansprüche, bei der das elastische Element (20) haftend an der ersten Schicht (16) befestigt ist.
8. Rückhalteklappe gemäß einem der vorhergehenden Ansprüche, bei der die erste und die zweite Schicht (16,18) nicht integral ausgebildet sind.
9. Rückhalteklappe gemäß einem der vorhergehenden Ansprüche, bei der das elastische Element (20) intermittierend an der ersten und/oder der zweiten Schicht (16,18) thermisch befestigt ist.
10. Rückhalteklappe gemäß einem der vorhergehenden Ansprüche, bei der das elastische Element (20) einen Schmelz- oder Zersetzungspunkt aufweist, der höher ist als der Schmelzpunkt der ersten Schicht (16). 50
11. Rückhalteklappe gemäß einem der vorhergehenden Ansprüche, bei der der Schmelz- oder Zersetzungspunkt des elastischen Elements (20) wenigstens 5°C höher liegt als der Schmelzpunkt der ersten Schicht (16). 55
12. Rückhalteklappe gemäß einem der vorhergehenden Ansprüche, bei der das elastische Element

- (20) intermittierend an der ersten und der zweiten Schicht (16,18) thermisch befestigt ist.
13. Rückhalteklappe gemäß einem der vorhergehenden Ansprüche, bei der die Rückhalteklappe (10) ein erstes Muster von thermischen Verklebungen (22) aufweist, welche die erste und die zweite Schicht (16,18) miteinander verbinden, wobei das erste Muster von thermischen Verklebungen (22) benachbart zur distalen Kante (14) angeordnet ist.
14. Rückhalteklappe gemäß einem der vorhergehenden Ansprüche, bei der die Rückhalteklappe (10) ein zweites Muster von thermischen Verklebungen (26) aufweist, welche die erste und die zweite Schicht (16,18) miteinander verbinden, wobei das zweite Muster von thermischen Verklebungen (26) benachbart zu dem ersten Muster thermischer Verklebungen (22) und zwischen dem ersten Muster thermischer Verklebungen (22) und der proximalen Kante (12) angeordnet ist.
15. Rückhalteklappe gemäß einem der vorhergehenden Ansprüche, bei der das elastische Element (20) nicht haftend an der ersten oder der zweiten Schicht (16,18) befestigt ist.
16. Rückhalteklappe gemäß einem der Ansprüche 9 bis 15, bei der das elastische Element (20) während der intermittierenden, thermischen Befestigung des elastischen Elements (20) an der ersten und/oder der zweiten Schicht (16,18) weder geschmolzen noch zersetzt wird.
17. Rückhalteklappe gemäß einem der Ansprüche 6 bis 16, die des weiteren ein zweites elastisches Element (20) umfaßt, welches zwischen dem ersten und dem zweiten Muster thermischer Verklebungen (22,26) angeordnet ist, wobei das zweite elastische Element (20) intermittierend an der ersten und der zweiten Schicht (16,18) thermisch befestigt ist.
18. Rückhalteklappe gemäß einem der vorhergehenden Ansprüche, bei der das elastische Element (20) einen elastomeren Faden aufweist oder ein elastomerer Faden ist.
19. Rückhalteklappe gemäß Anspruch 18, bei der der elastomere Faden einen Schmelz- oder Zersetzungspunkt aufweist, welcher höher als der Schmelzpunkt der ersten und der zweiten Schicht (16,18) ist.
20. Rückhalteklappe gemäß einem der vorhergehenden Ansprüche, bei der die erste und die zweite Schicht (16,18) aus einem wärmeschmelzbaren Material aus einem einzigen integralen Material-
- stück mittels Faltung gebildet sind.
21. Rückhalteklappe gemäß einem der vorhergehenden Ansprüche, bei der die Rückhalteklappe (10) des weiteren ein zweites elastisches Element (20) aufweist, welches zwischen dem ersten und dem zweiten Muster thermischer Verklebungen (22,26) angeordnet ist.
22. Saugfähiger Artikel (32), welcher die Rückhalteklappe gemäß einem der Ansprüche 1 bis 21 aufweist.
23. Saugfähiger Artikel (32) gemäß Anspruch 22 mit einem vorderen Bereich (34), einem hinteren Bereich (36) und einem Schrittbereich (38), welcher den vorderen und den hinteren Bereich (34,36) verbindet, wobei der Schrittbereich (38) gegenüberliegende Längsseitenbereiche (40) aufweist, wobei der Artikel (32) umfaßt:
- eine körperseitige flüssigkeitsdurchlässige Ausfütterung (44);
- eine äußere Abdeckung (42);
- einen saugfähigen Kern (46), welcher zwischen der körperseitigen Ausfütterung (44) und der äußeren Abdeckung (42) angeordnet ist; und
- ein Paar Rückhalteklappen (10), welche sich in Längsrichtung von dem vorderen Bereich (34) zum hinteren Bereich (36) erstrecken, wobei die proximale Kante (12) der Rückhalteklappe (10) mit der körperseitigen Ausfütterung (44) in dem Schrittbereich (38) und dem vorderen und dem hinteren Bereich (34,36) verbunden ist.
24. Verfahren zur Herstellung einer Rückhalteklappe gemäß einem der Ansprüche 1 bis 21 zur Verwendung auf einem saugfähigen Artikel, wobei das Verfahren die folgenden Schritte umfaßt:
- Bereitstellung einer ersten Schicht aus wärmeschmelzbarem Material, welches sich in eine erste Richtung bewegt;
- Befestigung von zwei elastischen Elementen, welche sich in die erste Richtung zu der ersten Schicht hin lateral voneinander beabstandet bewegen;
- thermisches Verkleben einer zweiten Schicht aus wärmeschmelzbarem Material, welche sich in die erste Richtung zu der ersten Schicht hin bewegt, zur Bildung eines Verbundmaterials, welches eine erste und eine zweite Längs-

- seitenkante aufweist, derart, daß das elastische Element zwischen der ersten und der zweiten Schicht angeordnet ist und ein erstes Muster von thermischen Verklebungen zwischen den elastischen Elementen angeordnet ist; 5
- Schlitzten des Verbundmaterials in der ersten Richtung zwischen den elastischen Elementen, zur Bildung von zwei geschlitzten Verbundmaterialien; und 10
- Schneiden der geschlitzten Verbundmaterialien in eine zweiten Richtung senkrecht zu der ersten Richtung zur Bildung von Rückhalteklappen. 15
25. Verfahren gemäß Anspruch 24, bei dem die erste Schicht aus wärmeschmelzbarem Material ein Vliesstoffmaterial ist. 20
26. Verfahren gemäß Anspruch 24 oder 25, bei dem die zweite Schicht aus wärmeschmelzbarem Material eine flüssigkeitsundurchlässige Folie aufweist. 25
27. Verfahren gemäß einem der Ansprüche 24 bis 26, bei dem vier elastische Elemente lateral voneinander beabstandet an der ersten Schicht befestigt sind. 30
28. Verfahren gemäß einem der Ansprüche 24 bis 27, bei dem ein zweites Muster thermischer Verklebungen zwischen der ersten Längsseitenkante des Verbundmaterials und einem der elastischen Elemente, welche sich am nächsten zu der ersten Längsseitenkante befindet, und zwischen der zweiten Längsseitenkante des Verbundmaterials und einem der elastischen Elemente, welches sich am nächsten zu der zweiten Längsseitenkante befindet, angeordnet ist. 35
29. Verfahren gemäß einem der Ansprüche 24 bis 28, bei dem die elastischen Elemente haftend an der ersten Schicht befestigt sind. 40
30. Verfahren gemäß einem der Ansprüche 24 bis 29, bei dem die elastischen Elemente intermittierend an der ersten und der zweiten Schicht aus wärmeschmelzbarem Material thermisch befestigt sind. 45
31. Verfahren gemäß einem der Ansprüche 24 bis 30, bei dem die elastischen Elemente elastomere Fäden sind. 50
32. Verfahren gemäß einem der Ansprüche 24 bis 31, bei dem die elastischen Elemente einen Schmelz- oder Zersetzungspunkt aufweisen, der höher liegt als der Schmelzpunkt der ersten Schicht. 55
33. Verfahren gemäß einem der Ansprüche 24 bis 32, bei dem die elastischen Elemente einen Schmelz- oder Zersetzungspunkt aufweisen, der wenigstens 5°C über dem Schmelzpunkt der ersten Schicht liegt.
34. Verfahren zu Herstellung einer Rückhalteklappe gemäß einem der Ansprüche 1 bis 21 zur Verwendung auf einem saugfähigen Artikel, wobei das Verfahren die folgenden Schritte umfaßt:
- Bereitstellung eines einzigen integralen wärmeschmelzbaren Materialstücks;
- Falten des wärmeschmelzbaren Materialstücks, um eine erste und eine zweite Schicht aus wärmeschmelzbarem Material bereitzustellen;
- Positionierung eines elastischen Elements zwischen der ersten und der zweiten Schicht aus wärmeschmelzbarem Material; und
- intermittierende thermische Verklebung des elastischen Elements mit der ersten und der zweiten Schicht.

Revendications

1. Volet de retenue (10) destiné à être utilisé dans un article absorbant, ledit volet de retenue (10) ayant un bord proximal (12), adapté à être réuni audit article absorbant, et un bord distal (14) à l'opposé dudit bord proximal (12), ledit volet de retenue (10) comprenant :
- une première couche (16) ;
 - une deuxième couche (18) ;
 - au moins un élément élastique (20) situé entre ladite première et ladite deuxième couches au voisinage dudit bord distal (14) ; et
 - un premier motif de liaisons (22) réunissant ensemble lesdites première et deuxième couches (16, 18), ledit premier motif de liaisons (22) étant situé entre ledit élément élastique (20) et ledit bord distal (14), caractérisé en ce que :
- lesdites première et deuxième couches (16, 18) sont faites d'un matériau thermofusible et ledit premier motif de liaisons (22) est fourni par des liaisons thermiques.
2. Volet de retenue selon la revendication 1, dans lequel ladite première couche (16) est faite d'un matériau non tissé.
3. Volet de retenue selon la revendication 1 ou 2, dans lequel ladite deuxième couche (18) est faite d'un

matériau non tissé.

4. Volet de retenue selon l'une des revendications précédentes, dans lequel ladite deuxième couche (18) est faite d'un film. 5
5. Volet de retenue selon l'une des revendications précédentes, dans lequel ledit volet de retenue (10) comprend deux éléments élastiques (20). 10
6. Volet de retenue selon l'une des revendications précédentes, comprenant en outre un deuxième motif de liaisons thermiques (26) situé entre ledit élément élastique (20) et ledit bord proximal (12). 15
7. Volet de retenue selon l'une des revendications précédentes, dans lequel ledit élément élastique (20) est fixé par adhésif à ladite première couche (18).
8. Volet de retenue selon l'une des revendications précédentes, dans lequel lesdites première et deuxième couches (16, 18) ne sont pas faites d'un seul tenant. 20
9. Volet de retenue selon l'une des revendications précédentes, dans lequel ledit élément élastique (20) est fixé thermiquement, par intermittence, auxdites première et/ou deuxième couche (16, 18). 25
10. Volet de retenue selon l'une des revendications précédentes, dans lequel ledit élément élastique (20) a un point de fusion ou de décomposition supérieur au point de fusion de ladite première couche (16). 30
11. Volet de retenue selon l'une des revendications précédentes, dans lequel le point de fusion ou de décomposition dudit élément élastique (20) est au moins 5°C supérieur au point de fusion de ladite première couche (16). 35
12. Volet de retenue selon l'une des revendications précédentes, dans lequel ledit élément élastique (20) est fixé thermiquement, par intermittence, auxdites première et deuxième couches (16, 18). 40
13. Volet de retenue selon l'une des revendications précédentes, dans lequel ledit volet de retenue (10) comporte un premier motif de liaisons thermiques (22) réunissant ensemble lesdites première et deuxième couches (16, 18), ledit premier motif de liaisons thermiques (22) étant adjacent audit bord distal (14). 45
14. Volet de retenue selon l'une des revendications précédentes, dans lequel ledit volet de retenue (10) comporte un deuxième motif de liaisons thermiques (26) réunissant ensemble lesdites première et deuxième couches (16, 18), ledit deuxième motif de liaisons thermiques (26) étant situé au voisinage dudit premier motif de liaisons thermiques (22) et entre ledit premier motif de liaisons thermiques (22) et ledit bord proximal (12). 50
15. Volet de retenue selon l'une des revendications précédentes, dans lequel ledit élément élastique (20) est fixé de manière non adhésive à ladite première ou deuxième couche (16, 18). 55
16. Volet de retenue selon l'une des revendications 9 à 15, dans lequel ledit élément élastique (20) n'est pas fondu ou décomposé au cours de la fixation thermique intermittente dudit élément élastique (20) auxdites première et/ou deuxième couches (16, 18).
17. Volet de retenue selon l'une des revendications 6 à 16, comprenant en outre un deuxième élément élastique (20) situé entre lesdits premier et deuxième motifs de liaisons thermiques (22, 26), ledit deuxième élément élastique (20) étant fixé thermiquement, par intermittence, auxdites première et deuxième couches (16, 18).
18. Volet de retenue selon l'une des revendications précédentes, dans lequel ledit élément élastique (20) comprend, ou est constitué par, un fil élastomère.
19. Volet de retenue selon la revendication 18, dans lequel ledit fil élastomère a un point de fusion ou de décomposition supérieur au point de fusion desdites première et deuxième couches (16, 18).
20. Volet de retenue selon l'une des revendications précédentes, dans lequel lesdites première et deuxième couches (16, 18) de matériau thermofusible sont formées, d'un seul tenant, à partir d'une unique pièce de matériau, par pliage.
21. Volet de retenue selon l'une des revendications précédentes, dans lequel ledit volet de retenue (10) comprend en outre un deuxième élément élastique (20) situé entre lesdits premier et deuxième motifs de liaisons thermiques (22, 26).
22. Article absorbant (32) comprenant le volet de retenue selon l'une des revendications 1 à 21.
23. Article absorbant (32) selon la revendication 22, ayant une portion avant (34), une portion arrière (36) et une portion d'entrejambe (38) connectant lesdites portions avant et arrière (34, 36), ladite portion d'entrejambe (38) ayant des portions latérales longitudinales opposées (40), ledit article (32) comprenant :
- un doublure côté corporel perméable aux liqui-

- des (44) ;
- une enveloppe extérieure (42) ;
 - un noyau absorbant (46) situé entre ladite doublure côté corporel (44) et ladite enveloppe extérieure (42) ; et
 - une paire de volets de retenue (10) s'étendant longitudinalement à partir de ladite portion avant (34) vers ladite portion arrière (36), ledit bord proximal (12) dudit volet de retenue (10) étant réuni à ladite doublure côté corporel (44) dans ladite portion d'entrejambe (38) et dans lesdites portions avant et arrière (34, 36).
24. Procédé de fabrication d'un volet de retenue selon l'une des revendications 1 à 21 pour une utilisation dans un article absorbant, ledit procédé comprenant les étapes suivantes :
- la fourniture d'une première couche d'un matériau thermofusible se déplaçant selon une première direction ;
 - la fixation à ladite première couche, selon une relation espacée latéralement, de deux éléments élastiques se déplaçant selon ladite première direction ;
 - la liaison thermique à ladite première couche d'une deuxième couche de matériau thermofusible se déplaçant selon ladite première direction pour former un composite ayant un premier et un second bords latéraux longitudinaux, de telle sorte que ledit élément élastique est situé entre lesdites première et deuxième couches et qu'un premier motif de liaisons thermiques est situé entre lesdits éléments élastiques ;
 - la fente dudit composite selon ladite première direction entre lesdits éléments élastiques pour former deux composites fendus ; et
 - la découpe desdits composites fendus selon une deuxième direction perpendiculaire à ladite première direction pour former des volets de retenue.
25. Procédé selon la revendication 24, dans lequel ladite première couche de matériau thermofusible est un matériau non tissé.
26. Procédé selon la revendication 24 ou 25, dans lequel ladite deuxième couche de matériau thermofusible est formée d'un film imperméable aux liquides.
27. Procédé selon l'une des revendications 24 à 26, dans lequel quatre éléments élastiques sont fixés à ladite première couche selon une relation espacée latéralement.
28. Procédé selon l'une des revendications 24 à 27, dans lequel un deuxième motif de liaisons thermi-
- ques est situé entre ledit premier bord latéral longitudinal dudit composite et l'un desdits éléments élastiques le plus proche dudit premier bord latéral longitudinal et entre ledit second bord latéral longitudinal dudit composite et l'un desdits éléments élastiques le plus proche dudit second bord latéral longitudinal.
29. Procédé selon l'une des revendications 24 à 28, dans lequel lesdits éléments élastiques sont fixés par adhésif à ladite première couche.
30. Procédé selon l'une des revendications 24 à 29, dans lequel lesdits éléments élastiques sont fixés thermiquement, par intermittence, auxdites première et deuxième couches de matériau thermofusible.
31. Procédé selon l'une des revendications 24 à 30, dans lequel lesdits éléments élastiques sont des fils élastomères.
32. Procédé selon l'une des revendications 24 à 31, dans lequel lesdits éléments élastiques ont un point de fusion ou de décomposition supérieur au point de fusion de ladite première couche.
33. Procédé selon l'une des revendications 24 à 32, dans lequel lesdits éléments élastiques ont un point de fusion ou de décomposition au moins 5°C supérieur au point de fusion de ladite première couche.
34. Procédé de fabrication d'un volet de retenue selon l'une des revendications 1 à 21, pour une utilisation dans un article absorbant, ledit procédé comprenant les étapes suivantes :
- la fourniture d'une pièce unique d'un seul tenant d'un matériau thermofusible ;
 - le pliage de ladite pièce de matériau thermofusible pour créer une première et une deuxième couches de matériau thermofusible ;
 - le positionnement d'un élément élastique entre lesdites première et deuxième couches de matériau thermofusible ; et
 - la liaison thermique intermittente dudit élément élastique auxdites première et deuxième couches.

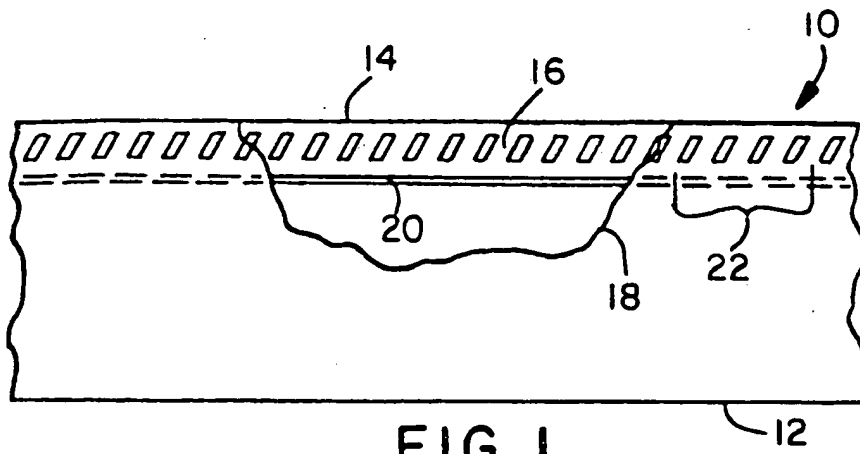

FIG. 1

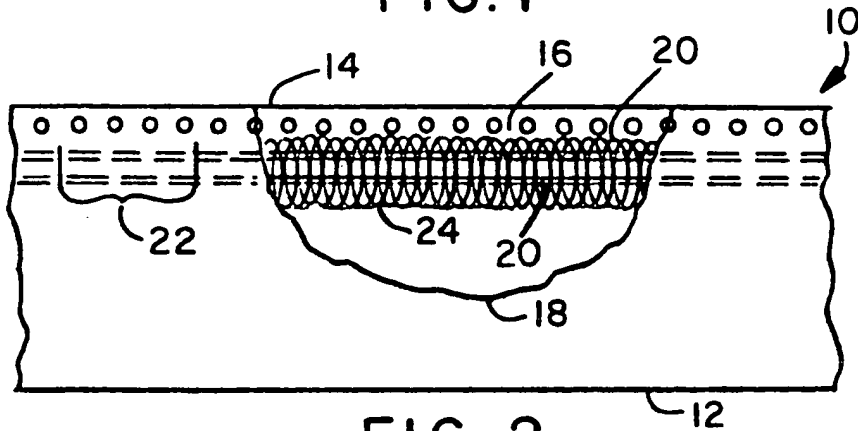

FIG. 2

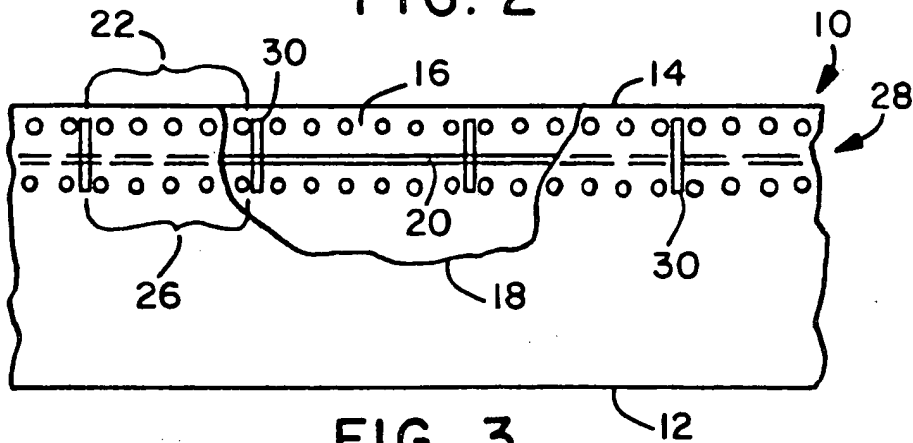

FIG. 3

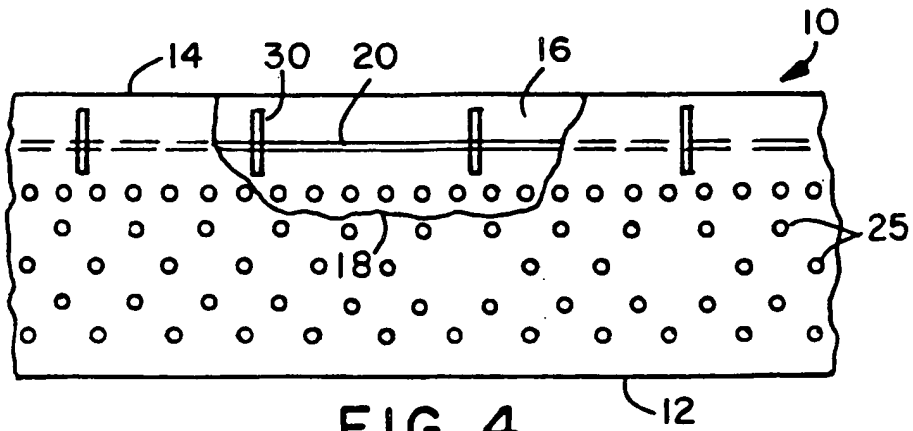

FIG. 4

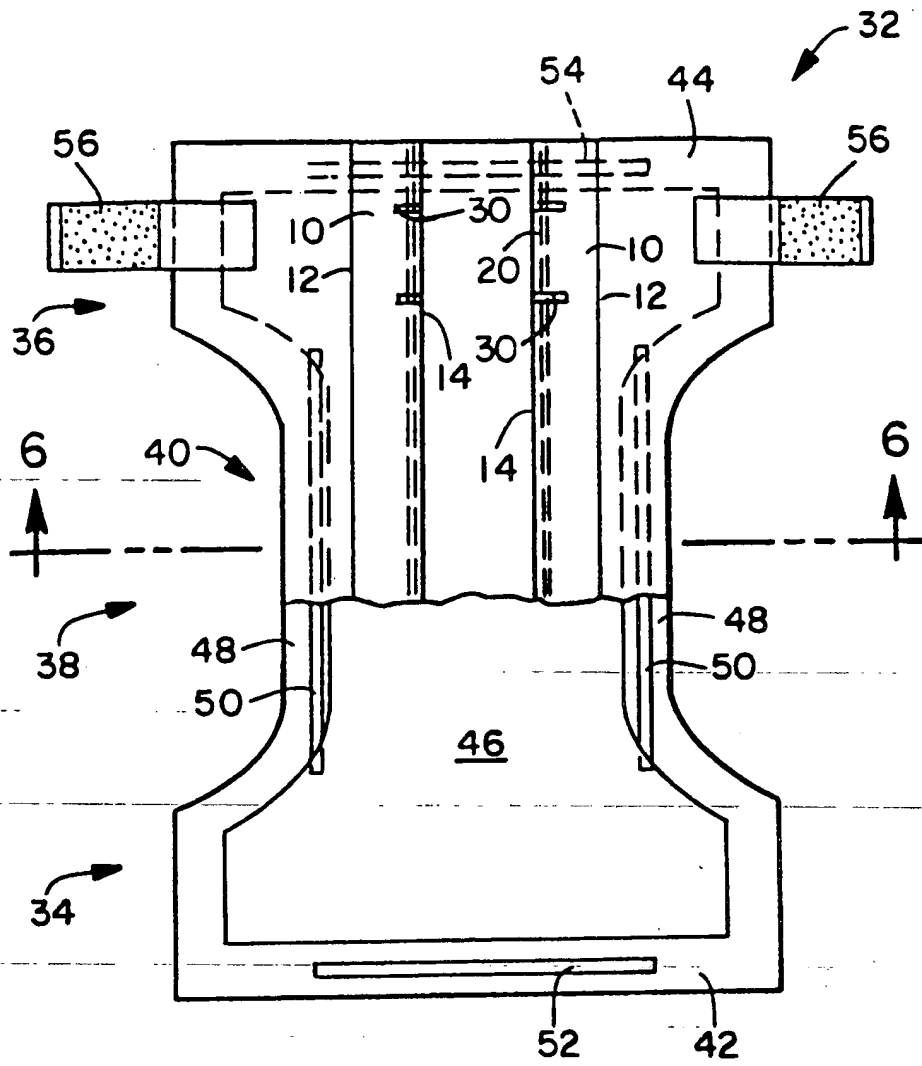

FIG. 5

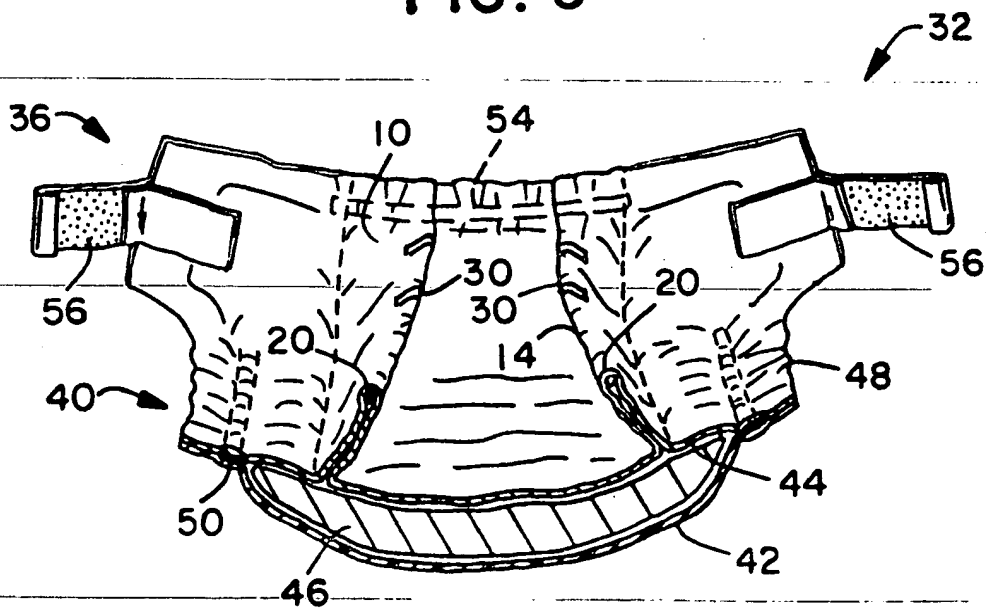

FIG. 6

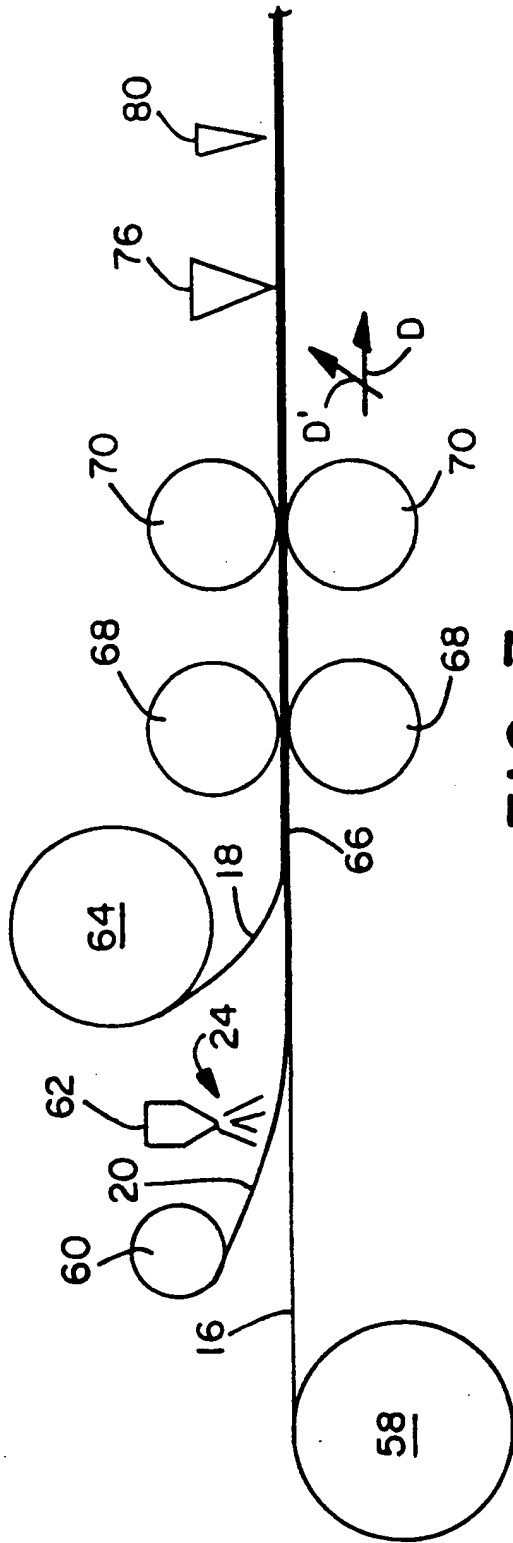

FIG. 7

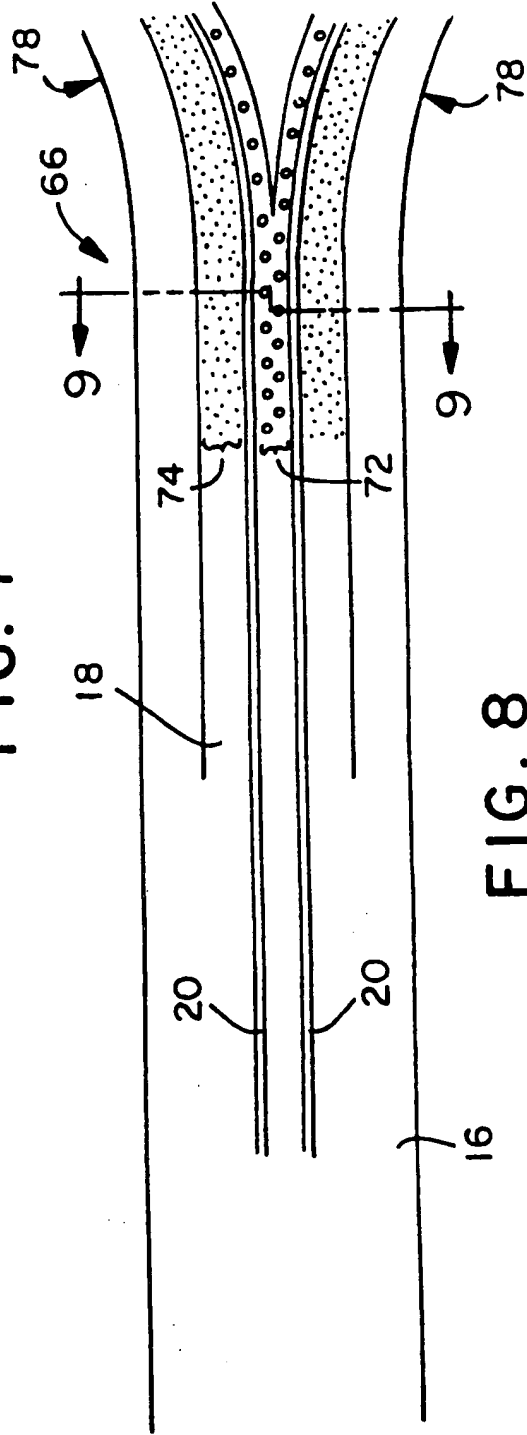

FIG. 8

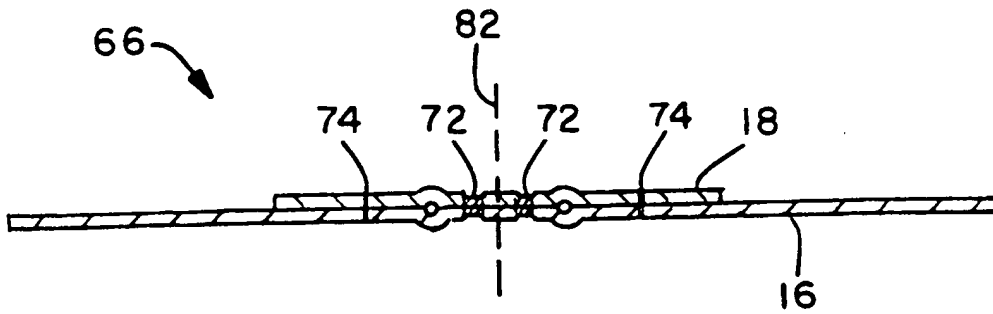

FIG. 9

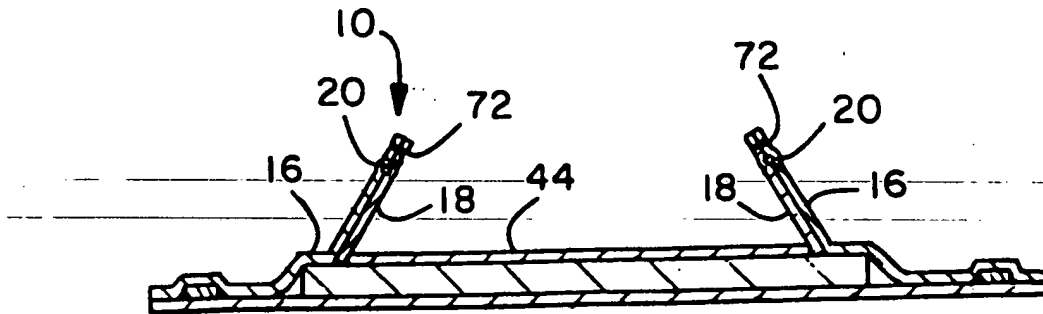

FIG. 10

THIS PAGE BLANK (USPTO)
